

# Webpass IP Reader Installation Guide

## A. Package content

### ■ PARTS

Controller X 1, Accessory kit X 1 ( Plastic screw X 3, Fastening screw X 3, 1N4004 X 1, Cable ( 2pin X 1, 4pin X 1, 5pin X 2, 8pin X 1 ) , CD X 1, Warranty card X 1 , Installation Guide X 1

## B. INSTALLATION

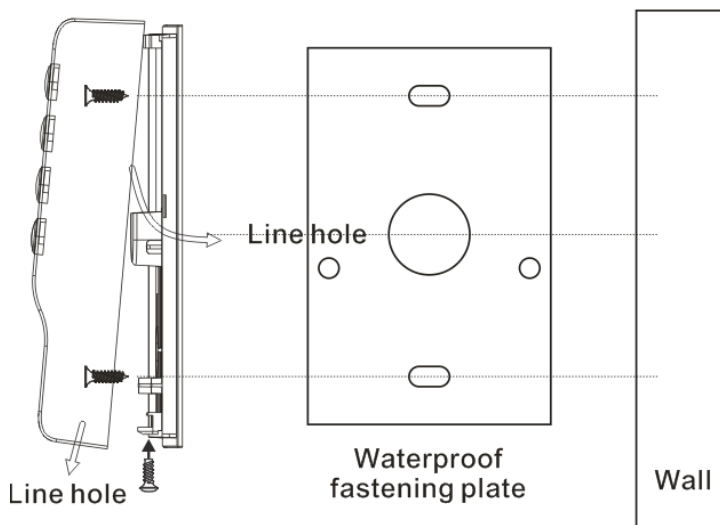

### ■ Physical Dimension

80 X 120 X 25 (mm)

### ■ Preparations

1. Wipe dust and wet from the wall.
2. Fasten the waterproof plastic plate on the wall.
3. Drill the holes indicating on the plastic plate.
4. Fasten the plate with plastic screws to each holes.

### ■

### ■ Using the line hole under side

1. Use the screw driver to open the back cover of host.
2. Install the back cover by using the screws which attached inside.
3. Please refer to process C to finish the installation.
4. Pass the cable through the line hole under side.
5. Combine the machine body, and then fix the screw under the machine.

### ■ Using the line hole at back cover

1. Use the screw driver to open the back cover of host.
2. Pass the cable through the line hole at the back cover.
3. Install the back cover by using the screws which attached inside.
4. Please refer to process C to finish the installation.
5. Combine the machine body, and then fix the screw under the machine.

## ■ RECOMMENDED

- Shielded type cable, Linear DC power adapter, Network cable.

## ■ SPECIFICATIONS

- Voltage range : 12-24V DC
- Current max. Average : 800 mA
- Max distance for Wiegand : 80M
- Dimension : 120mm x 80mm x 25mm
- Net Weight: 130±10g
- Operation Temperature: -20°C ~ +55°C
- Cardholder capacity : 20,000cards/ 60,000entries
- Effective Reader Distance : 7-12cm (125KHz)/ 3-5cm (13.56MHz Mifare)/ 3-5cm (HID)
- Support card type: EM/Mifare/HID
- Built-In Reader : Support IN-OUT reader operation
- Internetworking : Built-In TCP/IP Module at speed 10/100Mbps

## ■ Cable and Wiring specification:

1. External DC system power supply wire specification:

RVV3X 1.0mm shield wire is recommended to be used for external DC system power supply.  
(Thicker cable size is recommended for longer wiring deployment)

2. RS-485 Wire Specification:

RVVP2 X 0.75mm shielded wire is recommended. The wiring deployment should strictly follow the RS485 specification. The topology likes satellite, branch-like or T-Type will not be recommended. And the total wiring length of RS485 should NOT be over 1200M.

3. EM Lock Wire Specification

RVVP2 X 0.75mm shielded wire is recommended.

4. Exit Button/Door Sensor Wire Specification:

RVVP2 X 0.5mm shielded wire is recommended.

5. Card Reader wire specification:

RVVP6 X 0.5 mm shielded wire is recommended.

6. Wiegand wire specification:

Typical RVVP2 X 0.75 mm shielded wire is recommended. For longest distance for Wiegand is only up to 80M

7. Optimal vertical installation distance between devices:

EM type: 50cm only

Mifare type: 20cm only

Felica type: can be less than 5cm

Felica + Mifare type: can be less than 5cm

8. TCP/IP wire specification:

Cat-5 or Cat-5e (RJ-45 type) is recommended, longest deployment distance can be up to 100M.

## ■ Notice

- Do not connect other cable to the power unit except red & black power cable.
- Do not apply any unverified power supply to the unit or the hardware system may be damaged or may cause system an unstable condition.

# C. Terminal Block descriptions: J1~J8

## HW1.0

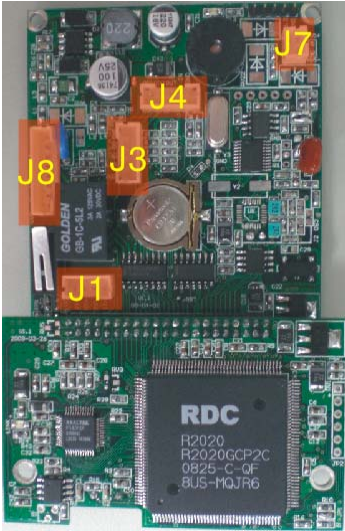

J8	1	VIN +	RED	POWER
	2	VIN -	BLACK	
	3	DOOR	VIOLET	EXIT BUTTON
	4	SENSOR	BLUE	SENSOR
	5	GND	PINK	GND
	6	NC	YELLOW	DOOR RELAY
	7	NO	WHITE	
	8	COM	LIGHT GREEN	

J7	1	485 +	BROWN	485
	2	485 -	GREY	

J4	1	OD1	BLACK WHITE	WIEGAND OUT
	2	OD0	RED WHITE	
	3	OUT	YELLOW WHITE	TTL(5V) output
	4	IN	BLUE WHITE	FIRE ALARM INPUT
	5	GND	PINK	GND

Cable		LAN Cable		RJ-45
1	RX +	BLACK	ORANGE WHITE	
2	RX -	RED	ORANGE	
3	TX +	GREEN	GREEN WHITE	
4	TX -	YELLOW	GREEN	

J3	1	GND	PINK	GND
	2	D0	WHITE RED	
	3	D1	WHITE BLACK	WIEGAND IN
	4	LED	YELLOW BLACK	
	5	BUZ	BLUE BLACK	

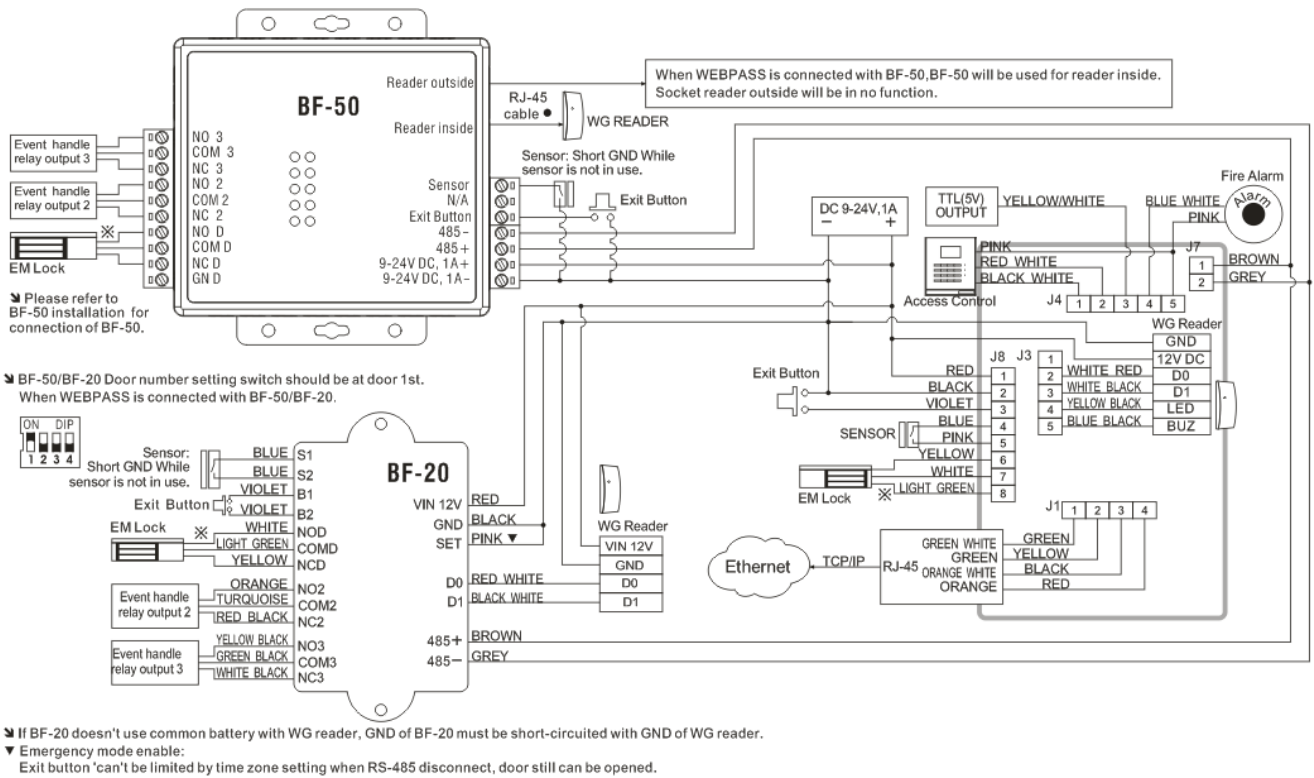

# HW1.1



J1	Cable		LAN Cable	
	1	TX+	BLACK	ORANGE WHITE
2	TX-	RED	ORANGE	
3	RX+	GREEN	GREEN WHITE	
4	RX-	YELLOW	GREEN	

J3	1	WID0	VIOLET WHITE	WIEGAND IN
	2	WID1	GREEN WHITE	
	3	GND	ORANGE	GND
	4	BUZZ	BLUE BLACK	Used to control LED and Buzzer of WG Reader
	5	LED	YELLOW BLACK	

J9	1	485-	GREY	485
	2	485+	BROWN	
	3	FGND	ORANGE	GND
	4	OD0	RED WHITE	WIEGAND OUT
	5	OD1	BLACK WHITE	
	6	GND	ORANGE	GND
	7	OUT	YELLOW WHITE	TTL(5V) output
	8	IN	BLUE WHITE	FIRE ALARM INPUT

J4	1	SENR	BLUE	SENSOR
	2	GND	ORANGE	GND
	3	DOOR	VIOLET	EXIT BUTTON
	4	NC	YELLOW	DOOR RELAY
	5	COM	GREEN	
	6	NO	WHITE	

J8	1	VIN-	BLACK	POWER
	2	VIN+	RED	

▼ BF-50/BF-20 Door number setting switch should be at door 1st.  
When WEBPASS is connected with BF-50/BF-20.



▼ If BF-20 doesn't use common battery with WG reader, GND of BF-20 must be short-circuited with GND of WG reader.

▼ Emergency mode enable:  
Exit button 'can't be limited by time zone setting when RS-485 disconnect, door still can be opened.

When WEBPASS is connected with BF-50, BF-50 will be used for reader inside. Socket reader outside will be in no function.

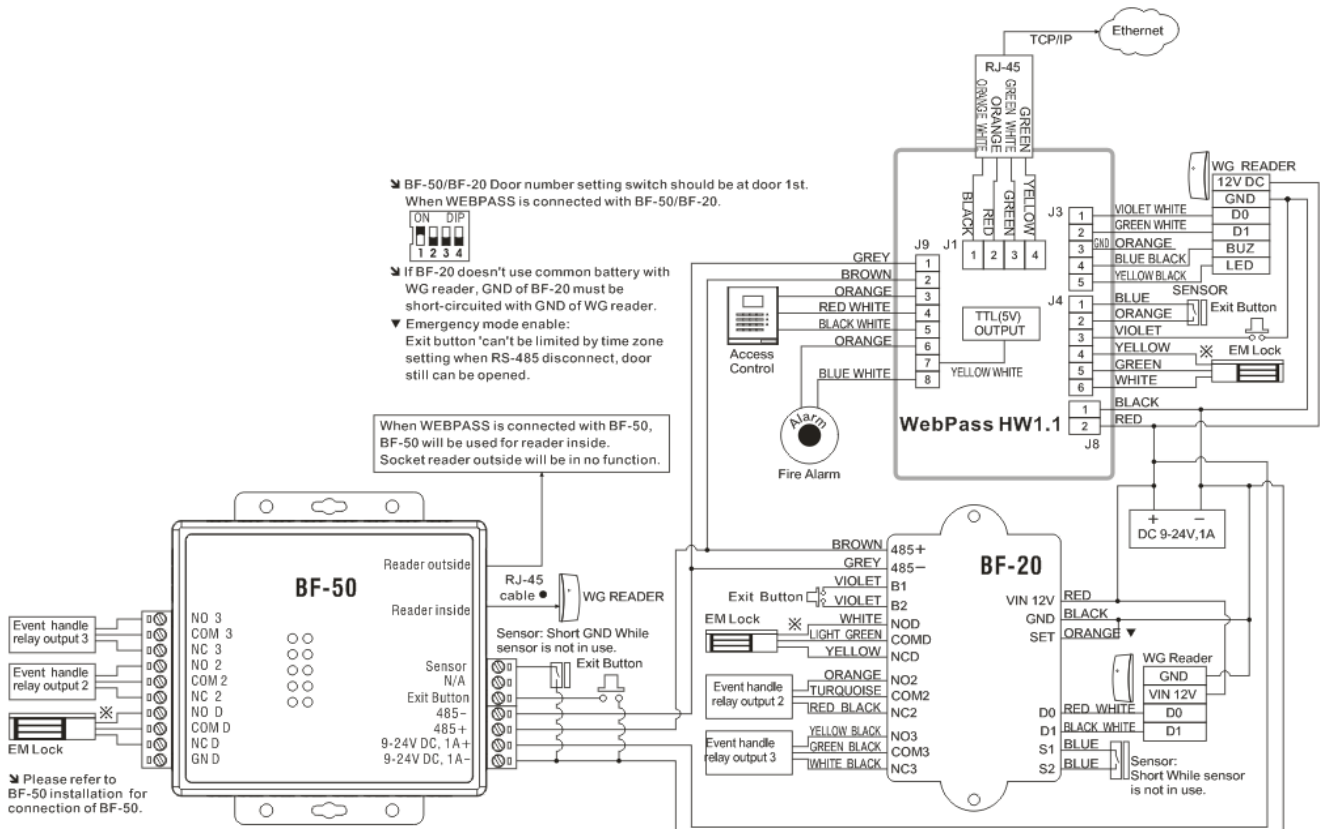

▼ Please refer to BF-50 installation for connection of BF-50.

## D. LED Indicators and Buzzer status descriptions:

	Red	Blue	Buzzer
Boot loader	Flash altogether per second		N/A
System Ready	N/A	Flash per second	2 short beep
System ready for Dummy Reader (Disconnected with SEMAC)	Both LED flash alternatively per second		N/A
Security Active (To be SEMAC reader)	Flash per second	N/A	N/A
Illegal card/password	Shine for 2 seconds	N/A	1 long beep
Registered card/password	N/A	Shine until door closed	1 short beep
Enforce to open/ Non Lock	N/A	Shine	N/A
Enforce to close	Shine	N/A	N/A
IP Conflict	Flash per second <sup>1</sup> + Keypad flash per second	N/A	1 short +1 long beep
Door open too long/Intrusion	Flash per second	N/A	Beep per second until door closed or Intrusion issue resolved
Command mode	Both LED flash altogether per second		1 short beep
Read card under command mode	Both LED flash alternatively per second		N/A
Modification failed	N/A	N/A	1 long beep
Device cover removed	N/A	Flash per second	Beep until cover installed
Waiting for next verification information (For example: Multiple verification Time zone= Card + Password: when card has been verified then KEYPAD flashes until Password input)	KEYPAD flashes per second (lasts 10seconds)		

## E. Command Mode:

### ■ Configuration Parameters :

UUUUUU : User ID Number ( 1~6 digits )

QQQQQQ : Number of Cards you want to register them in a process ( 1~6digits )

PPPPPPP : Password ( 4~8digits )

Command	Action
*123456#	Enter to Command mode : Initial password: 123456 , Buzzer long beeps after entered to command mode On Command Mode:: Blue and Red LEDs flash in the same time. After 10sec will back to Normal mode: Blue LED flashes per second Command Error: 1 long beep
02*TTTTT#	Door Open Relay configuration (Door close delay time) : Time for relay can be: 1-65535secs/ Default :10sec
03*TTTTT#	Door open waiting time(Door open delay time) : Time can be setting:1~65535 sec/Default:10sec
04*HHMMSS#	System Time setting : HHMMSS = Hour/Minute/Second(24H )
05*YYMMDDX#	System Date setting : YYMMDDX = Year/Month/Date/Weekday (YY=AD last two digit= 2009=09)
06*AAAAAA*BBBBBB*CCCCC C#	Password modification for entering Command Mode : AAAAAA : Old password BBBBBB : New password CCCCCC : New password like BBBBBB ※password is 4~6 digits
07*TTTTT#	Setting for TID nr. (Terminal ID) : TID nr. can be: 1 ~ 65535
08*T#	Access Control Setting : T= 0/1/2 → Normal Open/ Normal Close/Back to Normal
09*T#	Verification mode setting : T =1~4 1 : Card or Common Password 2 : Card only 3 : Common Password only 4 : Card and Personal password
10*PPPPPPP #	Common Password setting: 4~8 digits
11*UUUUUU*PPPPPPP #	Add a single User : Put the card to Reader * then enter the

	password#. If need no password then: 11*uuuuuu# only
12*UUUUUUU*QQQQQQ#	Add many Users: card numbers are continuous : Just Put the card with smallest card number to Reader
13*UUUUUUU*QQQQQQ#	Add many Users: Card numbers discontinuous : Put the cards one by one to Reader
14*UUUUUUU #	Inactive a user account(User status : Cancelled)
15*UUUUUUU #	Active a user account (User status: Active)
16* UUUUUUU*PPPPPPP #	User password modification: 4~8 digits
17*UUUUUUU#	Modify User Card Number
21*UUUUUUU #	Delete single user account
22*UUUUUUU *QQQQQQ #	Delete many/continuous user accounts
23*29*#	Delete All user accounts
*#	Exit from Command Mode